



**SERIES GVI  
AWWA C509/C515  
RESILIENT SEATED GATE VALVES  
2"-48"**



# Series GVI

Resilient Seated Gate Valves  
to AWWA C509/C515



## REPLACEABLE O-RINGS

Triple O-ring sealed with upper two O-rings replaceable with the valve fully open and subjected to the full rated pressure.

## INTEGRAL THRUST COLLAR

The forged shaft features an integral thrust collar with the wear surfaces being replaceable thrust bushings instead of the shaft itself.

## STAINLESS STEEL STEM

Stainless Steel 304 stems are standard on the Series GVI gate valve. The corrosion resistant Stainless Steel features high tensile strength for a long trouble free life. Additional options available tailored to line media compatibility.

## NO FLAT GASKETS

Formed seals at stuffing box and body to bonnet flanges ensure a good seal and allow easy service in the field.

## EASY STORAGE

Bodies feature flat pads on the bottom of all valves to hold the valve in the upright position during storage, preventing damage from outside elements.

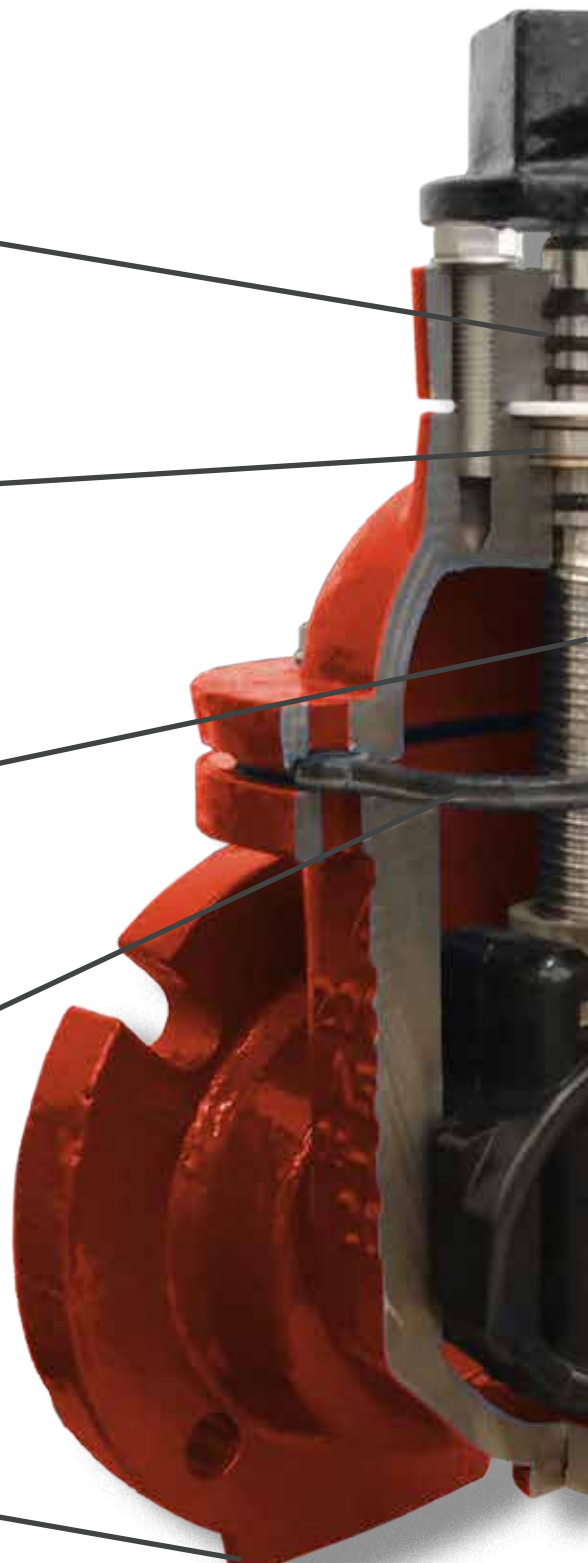

PAGE 2

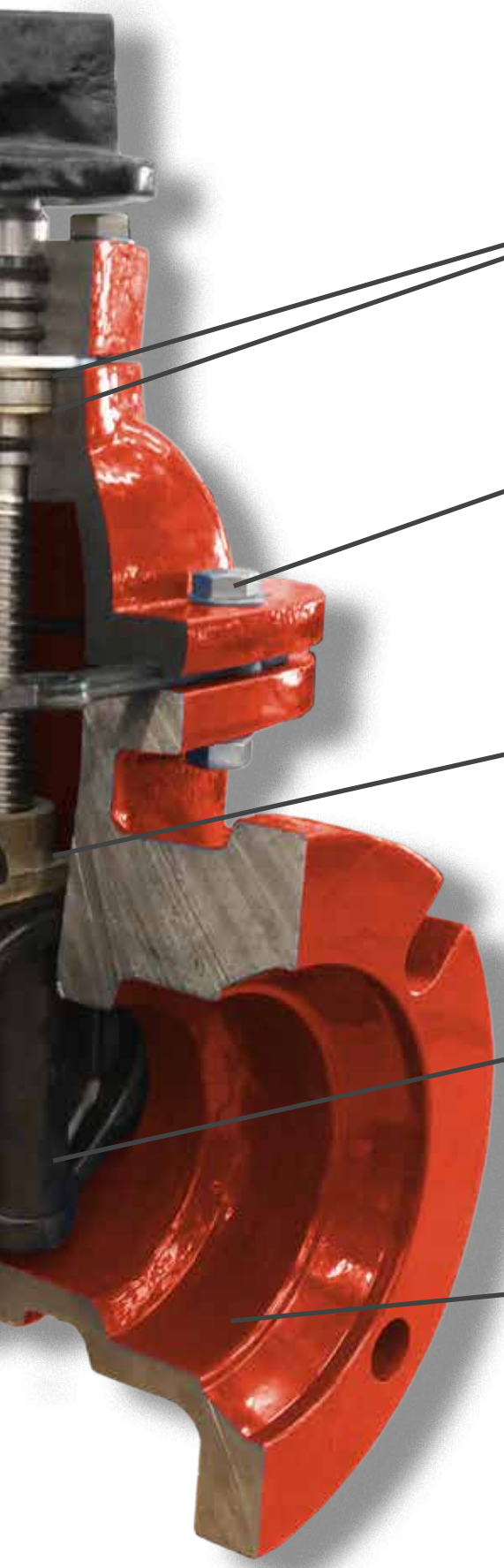

### THRUST BEARINGS

Replaceable thrust bearings above and below the thrust collar reduce operating friction and extend the life of the valve

### STAINLESS HARDWARE

Valves come standard with Stainless Steel 304 hardware for long service life in buried/submerged and harsh service conditions. Additional options available for corrosive and extreme exposures.

### COPPER ALLOY STEM NUT

The copper alloy stem nut assures there will be no seizing or galvanic corrosion between it and the stem, while also providing a convenient affordable failure point.

### FULLY ENCAPSULATED WEDGE

Standard Ductile Iron wedge fully encapsulated over 100% of surface ensuring a bubble-tight seal in the harshest of service and eliminating wedge corrosion

### EPOXY COATING

Valve is fully coated with a fusion-bonded epoxy conforming to AWWA C550 in traditional gate valve red. Suitable for buried service or field applied topcoats.

# Series GVI

Resilient Seated Gate Valves  
to AWWA C509/C515



## The VSI Advantage

All Series GVI Gate Valves come standard with the far superior Ductile Iron body and gate. The higher strength of Ductile Iron compared to Cast Iron allows all valves up to 24" to be rated to a full 250 psi. Additionally, by utilizing heavy duty thick wall castings to AWWA C509 and modern Ductile Iron as the material, valves comply with the requirements of both AWWA C509 and C515. VSI's series GVI valve is UL listed ANSI/NSF 61 & 372 for non-rising stem configurations with standard materials.



Size	AWWA C509	AWWA C515	Series GVI
2"-2.5"	NA	NA	250psi
3"-12"	200psi	200psi	250psi
14"-24"	150psi	200psi	250psi



As standard all Series GVI Gate Valves feature a one-piece forged shaft with an integral thrust collar supported in both directions by replaceable permanently lubricated thrust bearings. The one-piece shaft eliminates the seal damage and leakage that often occurs with gate valves that utilize a split ring collar to retain thrust. Shafts are stainless as standard, with many options available to meet project requirements.

All Series GVI Gate Valves utilize triple o-ring sealing to assure zero external leakage and ease of maintenance. The primary lower sealing o-ring rides in a recess on the shaft, facilitating easier replacement than o-rings that must be retrieved from a recess in the body.

The bronze stem nut provides a convenient failure point in the case of vandalism or excessive torque input. Over torque on the valve input will cause the replaceable stem nut to fail, leaving the shaft and valve body unharmed. The low coefficient of friction bronze stem nut also reduces friction, lowering the needed operating force required.



### Implementations

The Gate Valve has long been the standard for low cost full port isolation applications. The resilient seated variation of the Gate Valve adds the characteristic of zero-leak to this list. Operating torques in the Gate Valve are the lowest of any isolation valve relative to size.

### 100% Port Area

All VSI Resilient Seated Gate Valves come standard with a port area equal to 100 percent of the nominal pipe size port area. By including this feature as standard, valve flow coefficients are optimized across the entire line. The smooth full port body allows for minimal flow loss and lower pumping costs. Most standard full size tapping cutters are compatible with this valve design.



PAGE 5



### Resilient Gate Facing

The ductile iron wedge is fully encapsulated with high performance EPDM rubber by an advanced vulcanization process. This provides a permanent bond, maintains tight tolerances on the wedge, and provides excellent sealing performance. VSI's vulcanization process passes the ASTM D429 adhesion test. The resilient nature of the seat allows for drip-tight shut off. Should small solids become deposited upon the gate face, tight shut off is still guaranteed.



## Sample Specification

### Resilient Wedge Gate Valves for Waterworks Service

- 1.1. This specification covers the design, manufacture, and testing of cast resilient wedge gate valves 2 inch (75 mm) and larger under service pressure of up to 250 psig (1724 kPa).
- 1.2. Resilient wedge gate valves shall be resilient seated and of the non-rising stem type.
2. GOVERNING STANDARDS
  - 2.1. All resilient wedge gate valves shall be in full conformance with the design, manufacturing, and testing standards set forth by the American Water Works Association (AWWA) in Standard ANSI/AWWA C509 and ANSI/AWWA C515.
  - 2.2. When requested, manufacturer shall provide an Affidavit of Proof of Design Testing in accordance with AWWA.
3. CONNECTIONS
  - 3.1. Flanged valves shall conform to all standards of ANSI B16.1, Class 125 or Class 250.
  - 3.2. Flanged valves' lay length shall conform to ASME B16.10.
  - 3.3. Mechanical joint valves shall conform to all standards of ANSI/AWWA C111/A21.11.
4. MARKINGS
  - 4.1. Each valve shall be marked with the manufacturer's name, valve size, body material, and pressure rating cast into the body of the valve. Lettering shall be a minimum of 1/2 inch tall and project 1/10 inch from body.
  - 4.2. When requested resilient seated gate valves, except buried or submerged valves, shall be equipped with a tag identifying body, gate, resilient encapsulation, and stem material in addition to manufacturer's name, pressure rating, size, date of manufacturer, and date of testing.
5. DESIGN
  - 5.1. Valves shall be equipped with a gate fully encapsulated with a resilient seat bonded per ASTM D429.
  - 5.2. Valve stem shall be of the non-rising type an integral thrust collar. Split rings shall not be allowed on resilient seated gate valves
  - 5.3. Valve shall be equipped with a minimum of one seal or o-ring below the thrust collar and two above.
  - 5.4. Thrust bushings shall be supplied acting upon the integral thrust collar in both the opening and closing direction.
  - 5.5. The valve should have a smooth waterway equal to 100% ±5% the nominal pipe size.
  - 5.6. Valve sizes 36 inch and larger shall be equipped with an AWWA C509 bypass gate valve sized per AWWA C500 Table 11 when required.
  - 5.7. Valves 30 inch and larger where the final installation results in the valve stem being more than 22.5 degrees from vertical shall utilize friction reducing tracks and guides.
  - 5.8. The valves shall be equipped with a mounting area for operators conforming to Manufacturers Standard Society (MMS) 101 or International Organization of Standardization (ISO) 5211 if equipped with a gearbox, pneumatic, hydraulic, or electric actuator. There shall be sufficient clearance to directly mount standardized operators with easily accessible fasteners.
  - 5.9. Stem diameter at drive shall be the preferred dimension stated in ISO 5211 Table 4 for pneumatic, hydraulic, or electric actuators.
  - 5.10. Valves shall provide a bubble-tight shutoff bi-directionally at rated working pressure.
6. MATERIALS
  - 6.1. The valve body, gate, and bonnet if equipped shall be constructed of ASTM A536 Ductile Iron.
  - 6.2. The valve gate encapsulation shall be made from resilient NBR or EPDM as specified. The gate should be fully encapsulated with no voids and holiday tested before and after vulcanization.
  - 6.3. The stem shall be made of ASTM A276 type 304 or 316 stainless steel.
  - 6.4. Thrust bearings shall be made of permanently lubricated PTFE, or lead free Bronze.
  - 6.5. All submerged coatings shall conform to AWWA C550, be holiday free, and have a minimum total dry film thickness of 10 mils.
  - 6.6. All valves shall have type 304 or 316 stainless steel exterior hardware.
7. OPERATORS
  - 7.1. All manually operated valves 16 inches and larger shall be equipped with a bevel or spur gear actuator. Operator should be designed to hold the valve in any intermediate position without creeping.
  - 7.2. All actuators shall be permanently sealed and suitable for buried service.
  - 7.3. All 2 inch square operating nuts shall be epoxy coated or made of corrosion resistant stainless steel.
  - 7.4. All actuators equipped with handwheels shall have a maximum rim pull of 50lbs plus 5%.
8. MANUFACTURER
  - 8.1. Resilient seated wedge gate valves shall be VSI Series GVI as manufactured by Valve Solutions, Inc., Alpharetta, GA USA.
  - 8.2. All valves shall be warranted by manufacturer for a minimum of 12 months.



## Materials of Construction

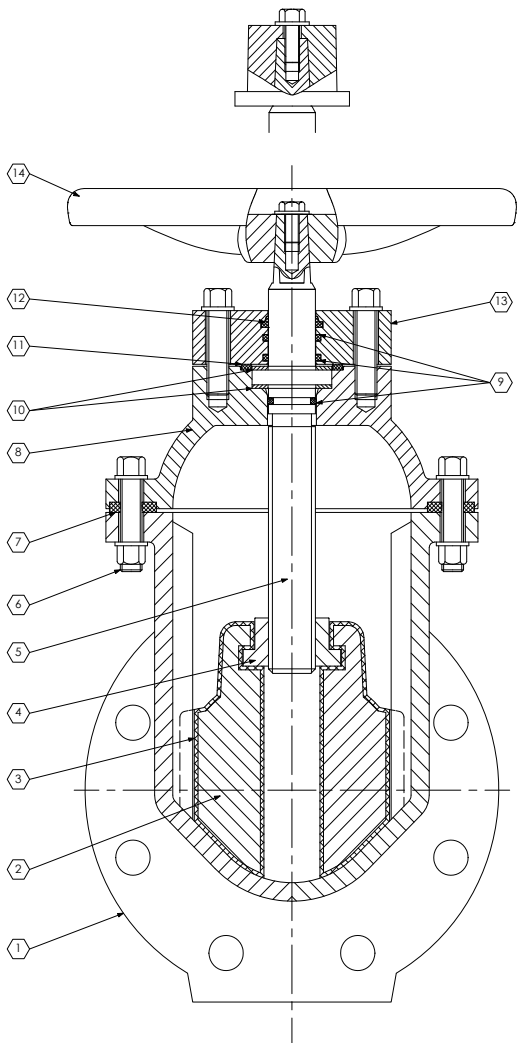

Item	Description	Materials Available	Standard
1	Body	Ductile Iron*	ASTM A536 65-45-12
		Cast Iron	ASTM A126 Class B
		Stainless Steel 304	ASTM A351 CF8
		Stainless Steel 316	ASTM A351 CF8M
		Carbon Steel	ASTM A216 WCB
2	Gate	Same as Body	
3	Encapsulation	EPDM*	
		Buna-N (NBR) Viton (FPM)	
4	Stem Nut	Bronze*	ASTM B16
		Naval Bronze	ASTM B21 C464
5	Stem	Stainless 304*	ASTM A276 304
		Stainless 316	ASTM A276 316
		Bronze	ASTM B16
		Stainless 416	ASTM A582 416
		17-4PH	ASTM A693 Grade 630
6	Exterior Hardware	Super Duplex 2507	ASTM A240 2507
		Stainless 304*	ASTM F593/594
		Stainless 316	ASTM F593/594
7	Body Seal	Plated Steel	ASTM A325 Type 1
		Bronze	C651
		Same as Encapsulation	
8	Upper Body	Same as Body	
9	O-Rings	Same as Encapsulation	
10	Bearings	PTFE*	
		Nylon	
		Bronze	ASTM B16
11	Cap/Mount Seal	Stainless 316	ASTM A276 316
		Same as Encapsulation	
12	Dust Seal	Same as Encapsulation	
13	Cap/Mount	Same as Body	
14	Operator	Same as Body	

PAGE 7

Additional material options available as special order.



### Design Standards

Size Range	2"-48" Flanged End 2"-48" MJ End 2"-48" Flanged x MJ
Construction	AWWA C509 and AWWA C515* ASME B16.34 API 598
Coatings	AWWA C550* ANSI/NSF 61 Compliant
Connections	ANSI B16.1 Class 125/ANSI B16.5 Class 150* ANSI B16.1 Class 250/ANSI B16.5 Class 300 ANSI/AWWA C111/A21.11 (MJ)* ISO 7005 National Pipe Thread (NPT) ANSI/ASME 1.20.1
Lay Length	ASME B16.10* (ex. MJ) ISO 5752
Bonnet	MSS SP-101* ISO 5211

\*Standard Option

**Available as:**  
Underwriters Lab Inc. listed  
**ANSI/NSF 61**  
Also classified  
**ANSI/NSF 372**  
**<MH60347>**



**WATER QUALITY**



American Water Works  
Association

### Resistance Guide

Designation	Common Names	Composition	Min/Max Temperature Range	General Properties	Resistant to:	Attached by:
EPDM	EPDM, EPM	Ethylene-propylene-diene Monomer	-40F/250F	Excellent ozone, chemical, and aging resistance. Poor resistance to petroleum-based fluids	Animal and vegetable oils, ozone, strong and oxidizing chemicals.	Mineral oils and solvents, aromatic hydrocarbons
NBR	NBR, Buna-N	Nitrile-butadiene	-30F/225F	Excellent resistance to petroleum-based fluids. Good physical properties	Many hydrocarbons, fats, oils, greases, hydraulic fluids, chemicals	Ozone, ketones, esters, aldehydes, chlorinated and nitro hydrocarbons
FPM	FPM, Viton®	Hexafluoropropylene-vinylidene fluoride	-10F/400F	Excellent oil and air resistances both at low and high temperatures. Very good chemical resistance	All aliphatic, aromatic, and halogenated hydrocarbons, acids, animal and vegetable oils	Ketones, low molecular weight esters and nitro containing compounds
PTFE	PTFE, Teflon®	Polytetrafluoro-ethylene	-100F/450F	Excellent abrasion resistance and chemically inert	Acids, harsh inorganic and organic chemicals, oils, oxidizing agents, and solvents	Molten alkali metals and fluorine at high temperatures



### Pressure/Temperature Ratings

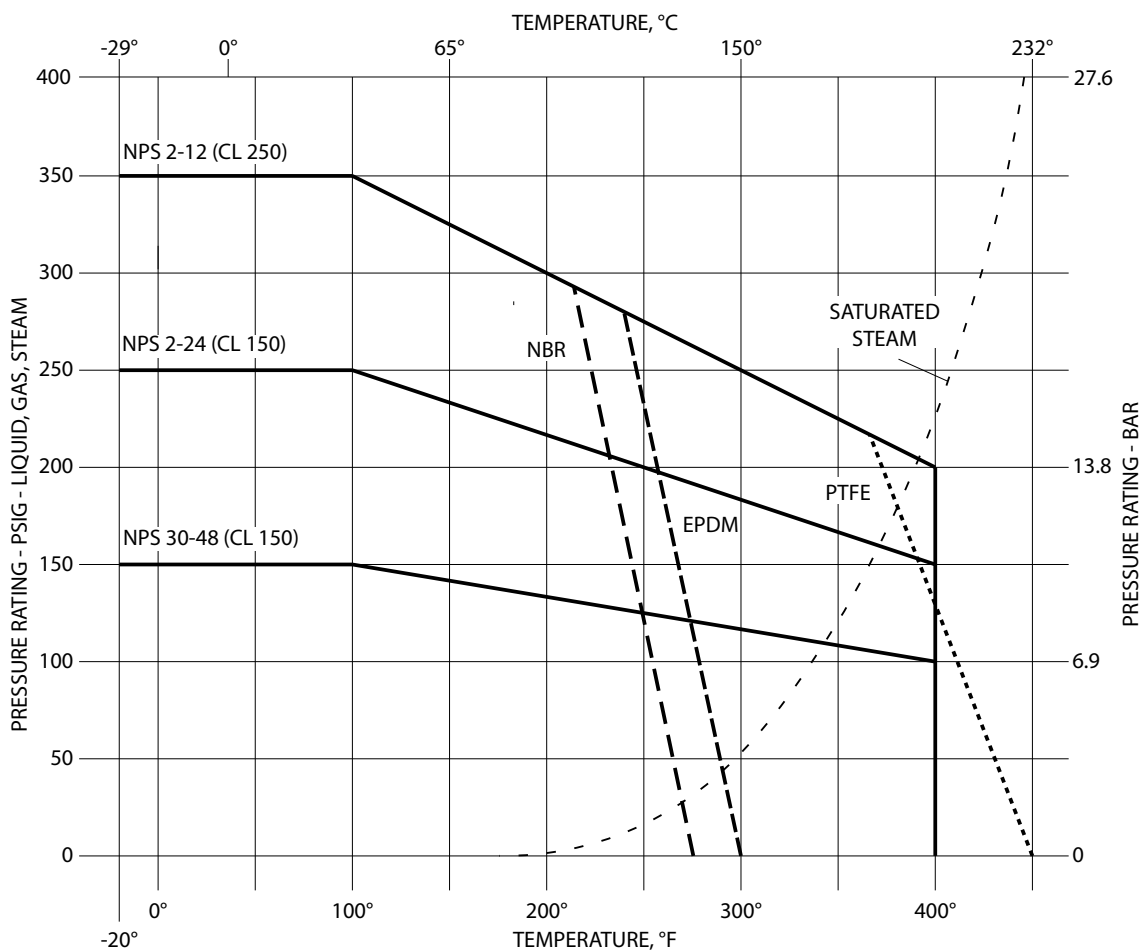

In determining field pressure ratings for Series GVI Gate Valves that are constructed of Ductile Iron the above chart should be used. Pressure cast on valve represents maximum seating pressure; maximum hydrostatic pressure is temperature dependent, and may be higher than nominal pressure rating.



## Flanged With Direct Handwheel

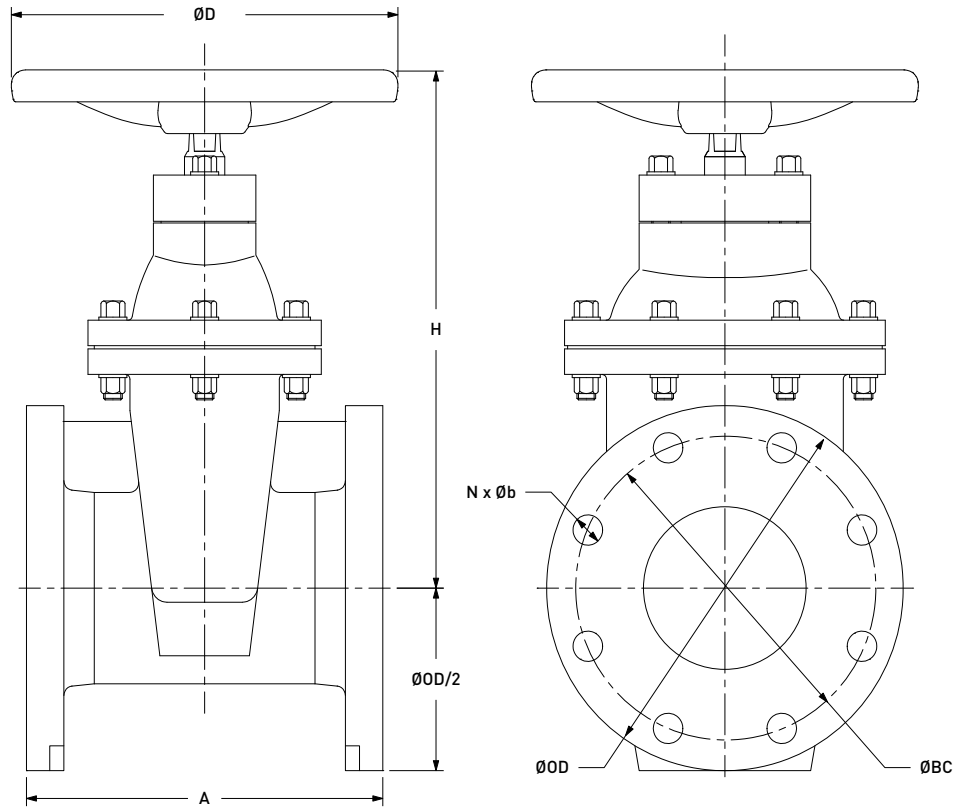

PAGE 10

SIZE	A	OD	BC	N	b	H	D	TURNS	WEIGHT
2"	7	6	4 3/4	4	3/4	10 3/8	8	8	33
2-1/2"	7 1/2	7	5 1/2	4	3/4	11 3/8	9	9	40
3"	8	7 1/2	6	4	3/4	12 1/2	9	11	46
4"	9	9	7 1/2	8	3/4	13 7/8	10	14	66
5"	10	10	8 1/2	8	7/8	16	10	17	93
6"	10 1/2	11	9 1/2	8	7/8	17 1/2	12	20	106
8"	11 1/2	13 1/2	11 3/4	8	7/8	21	14	27	185
10"	13	16	14 1/4	12	1	24 1/2	16	33	260
12"	14	19	17	12	1	27 3/8	16	39	364
14"	15	21	18 3/4	12	1 1/8	30 3/4	18	45	547
16"	16	23 1/2	21 1/4	16	1 1/8	33 3/4	18	52	683
18"	17	25	22 3/4	16	1 1/4	36 3/4	20	58	959
20"	18	27 1/2	25	20	1 1/4	39 3/4	20	64	1102
24"	20	32	29 1/2	20	1 3/8	46	20	77	1543

Gearbox recommended for valves larger than 14". Flanged valves available with nut operator as option.



### Flanged With Bevel Gear

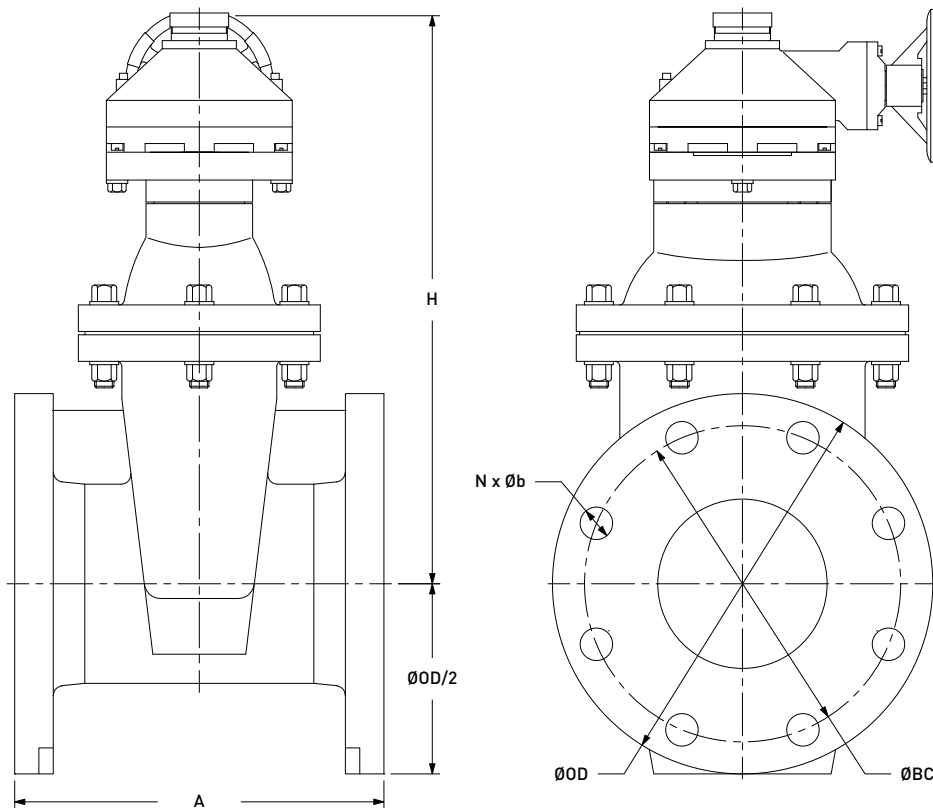

SIZE	A	OD	BC	N	b	H	TURNS*	WEIGHT
2"	7	6	4 3/4	4	3/4	16 5/8	23	-
2-1/2"	7 1/2	7	5 1/2	4	3/4	17 5/8	26	-
3"	8	7 1/2	6	4	3/4	18 5/8	33	-
4"	9	9	7 1/2	8	3/4	20	41	-
5"	10	10	8 1/2	8	7/8	22 1/8	51	-
6"	10 1/2	11	9 1/2	8	7/8	23 5/8	60	-
8"	11 1/2	13 1/2	11 3/4	8	7/8	27	79	-
10"	13	16	14 1/4	12	1	30 1/2	98	-
12"	14	19	17	12	1	27 3/8	117	-
14"	15	21	18 3/4	12	1 1/8	33 7/8	135	-
16"	16	23 1/2	21 1/4	16	1 1/8	39 3/4	153	-
18"	17	25	22 3/4	16	1 1/4	42 7/8	209	-
20"	18	27 1/2	25	20	1 1/4	46	235	-
24"	20	32	29 1/2	20	1 3/8	52 1/4	261	-

Apply for larger sizes to 48". Flanged valves available with nut operator as option.

\*Number of turns is applicable to current production model at time of document publish. Previously produced items or with specialty gearboxes may vary.



## Flanged With Spur Gear

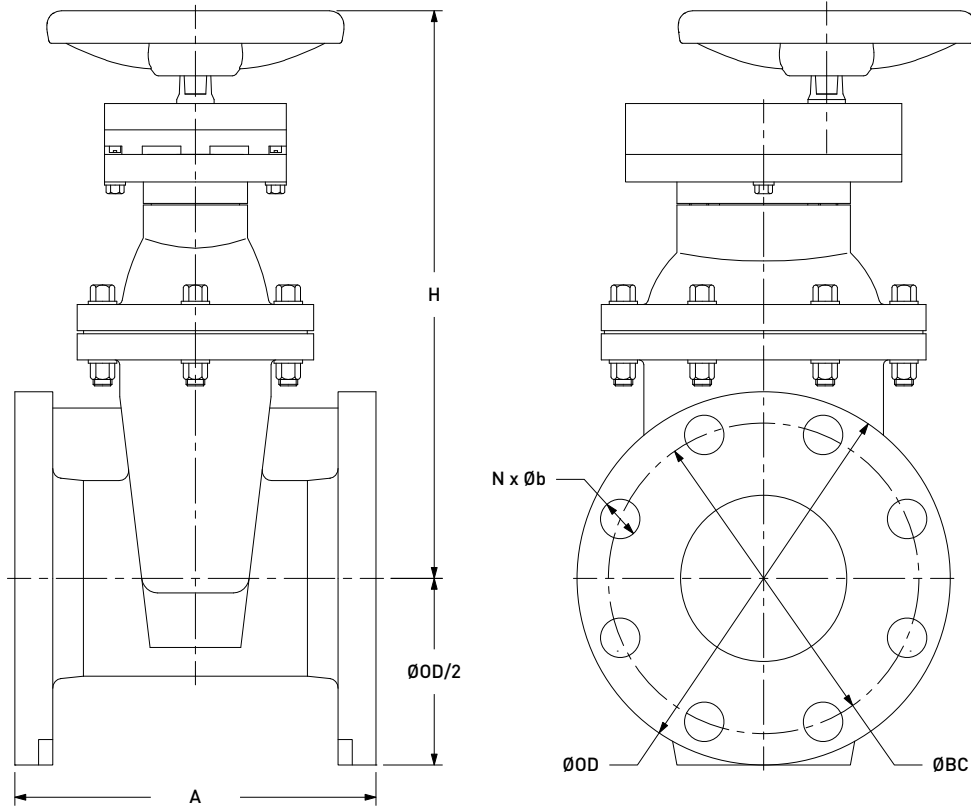

SIZE	A	OD	BC	N	b	H	TURNS*	WEIGHT
2"	7	6	4 3/4	4	3/4	16 5/8	23	-
2-1/2"	7 1/2	7	5 1/2	4	3/4	17 5/8	26	-
3"	8	7 1/2	6	4	3/4	18 5/8	33	-
4"	9	9	7 1/2	8	3/4	20	41	-
5"	10	10	8 1/2	8	7/8	22 1/8	51	-
6"	10 1/2	11	9 1/2	8	7/8	23 5/8	60	-
8"	11 1/2	13 1/2	11 3/4	8	7/8	27	79	-
10"	13	16	14 1/4	12	1	30 1/2	98	-
12"	14	19	17	12	1	27 3/8	117	-
14"	15	21	18 3/4	12	1 1/8	33 7/8	270	-
16"	16	23 1/2	21 1/4	16	1 1/8	39 3/4	306	-
18"	17	25	22 3/4	16	1 1/4	42 7/8	344	-
20"	18	27 1/2	25	20	1 1/4	46	381	-
24"	20	32	29 1/2	20	1 3/8	52 1/4	456	-

Apply for larger sizes to 48". Flanged valves available with nut operator as option.

\*Number of turns is applicable to current production model at time of document publish. Previously produced items or with specialty gearboxes may vary.



### Flanged With Actuator Mount

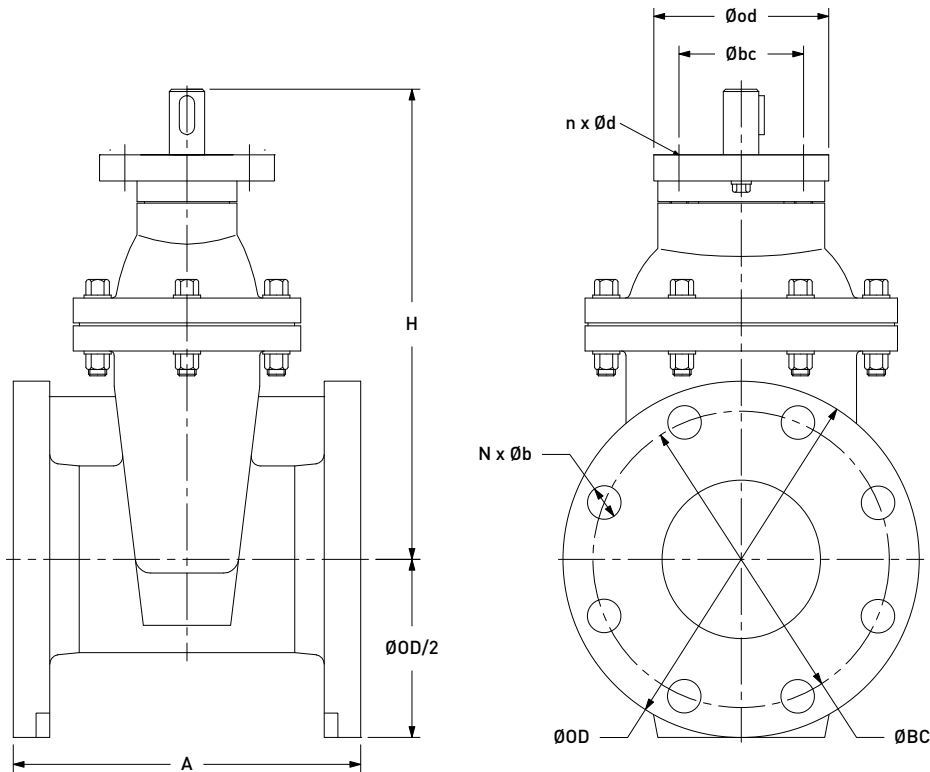

SIZE	A	OD	BC	N	b	H	D	MOUNT	od	bc	n	d	TURNS	WEIGHT
2"	7	6	4 3/4	4	3/4	9 2/5	8	F10	5	4	4	7/16	8	33
2-1/2"	7 1/2	7	5 1/2	4	3/4	10 1/2	9	F10	5	4	4	7/16	9	40
3"	8	7 1/2	6	4	3/4	11 2/3	9	F10	5	4	4	7/16	11	46
4"	9	9	7 1/2	8	3/4	13	10	F10	5	4	4	7/16	14	66
5"	10	10	8 1/2	8	7/8	15	10	F10	5	4	4	7/16	17	93
6"	10 1/2	11	9 1/2	8	7/8	16 3/5	12	F10	5	4	4	7/16	20	106
8"	11 1/2	13 1/2	11 3/4	8	7/8	19 8/9	14	F14	7	5 1/2	4	3/4	27	185
10"	13	16	14 1/4	12	1	23 1/2	16	F14	7	5 1/2	4	3/4	33	260
12"	14	19	17	12	1	26 3/5	16	F14	7	5 1/2	4	3/4	39	364
14"	15	21	18 3/4	12	1 1/8	32 2/7	18	F14	7	5 1/2	4	3/4	45	547
16"	16	23 1/2	21 1/4	16	1 1/8	35 2/5	18	F14	7	5 1/2	4	3/4	52	683
18"	17	25	22 3/4	16	1 1/4	39	20	F14	7	5 1/2	4	3/4	58	959
20"	18	27 1/2	25	20	1 1/4	42 1/2	20	F14	7	5 1/2	4	3/4	64	1102
24"	20	32	29 1/2	20	1 3/8	48 2/5	20	F14	7	5 1/2	4	3/4	77	1543

Apply for larger sizes to 48".



## Flanged Outside Stem and Yoke (OSY)

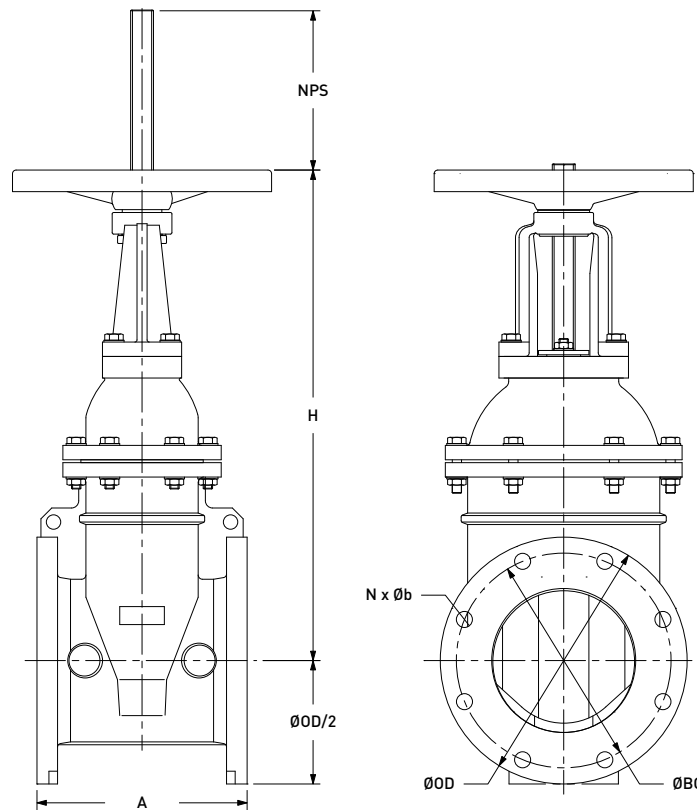

PAGE 14

SIZE	A	OD	BC	N	b	H	D	TURNS	WEIGHT
2"	7	6	4 3/4	4	3/4	11 5/8	8	8	-
2-1/2"	7 1/2	7	5 1/2	4	3/4	13	9	9	-
3"	8	7 1/2	6	4	3/4	14 3/8	10	11	-
4"	9	9	7 1/2	8	3/4	16 3/4	11	14	-
5"	10	10	8 1/2	8	7/8	20	11	17	-
6"	10 1/2	11	9 1/2	8	7/8	22 5/8	13	20	-
8"	11 1/2	13 1/2	11 3/4	8	7/8	29	14	27	-
10"	13	16	14 1/4	12	1	34	16	33	-
12"	14	19	17	12	1	39 1/4	18	39	-
14"	15	21	18 3/4	12	1 1/8	44 1/4	20	45	-
16"	16	23 1/2	21 1/4	16	1 1/8	49 1/2	20	52	-
18"	17	25	22 3/4	16	1 1/4	54 1/2	24	58	-
20"	18	27 1/2	25	20	1 1/4	59 5/8	24	64	-
24"	20	32	29 1/2	20	1 3/8	70	24	77	-

Gearbox recommended for valves larger than 16".



## Mechanical Joint With Direct Nut Operator

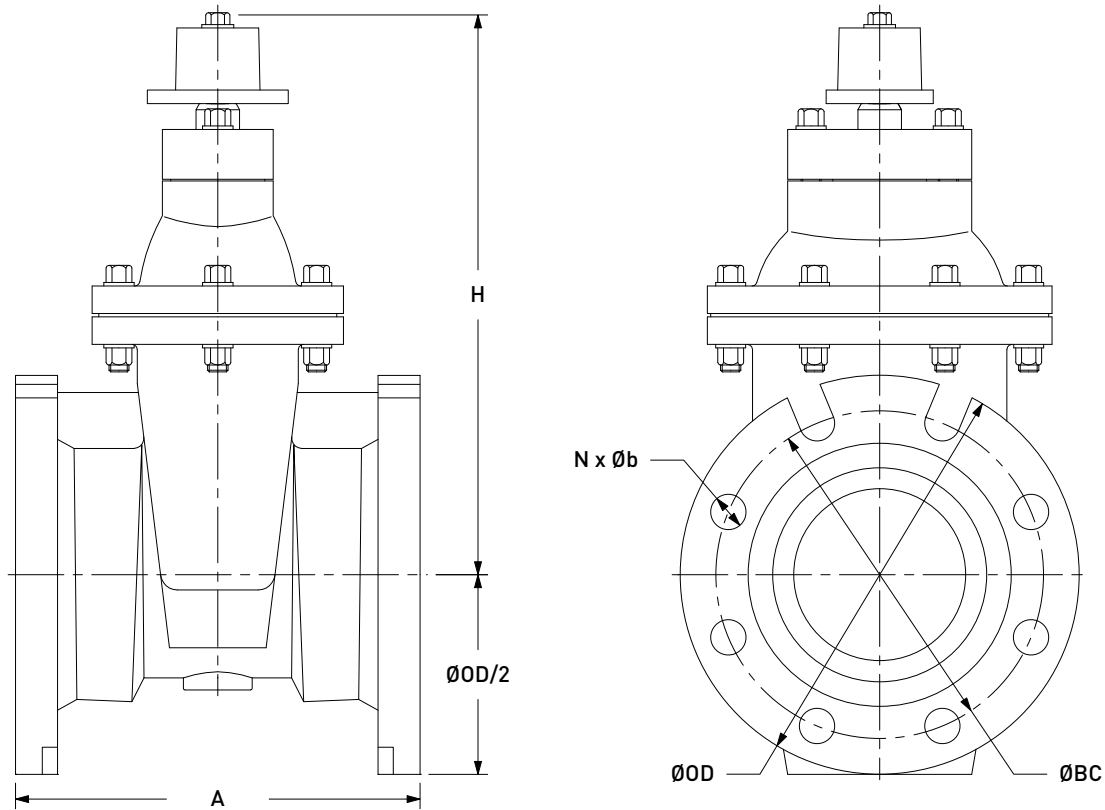

SIZE	A	OD	BC	N	b	H	TURNS	WEIGHT
2"	8 1/4	6.13	4 4/5	2	3/4	10 3/8	8	33
2-1/2"	8 1/4	6.75	5 2/5	2	3/4	11 3/8	9	40
3"	8 1/2	7.69	6 1/8	4	3/4	12 1/2	11	46
4"	9 1/2	9.12	7 1/2	4	7/8	13 7/8	14	66
6"	10	11.12	9 1/2	6	7/8	17 1/2	20	106
8"	10 1/2	13.37	11 3/4	6	7/8	21	27	185
10"	12	15.69	14	8	7/8	24 1/2	33	260
12"	13	17.94	16 1/4	8	7/8	27 3/8	39	364
14"	14	20.31	18 3/4	10	7/8	30 3/4	45	547
16"	18	22.56	21	12	7/8	33 3/4	52	683
18"	19 1/4	24.83	23 1/4	12	7/8	36 3/4	58	959
20"	20	27.08	25 1/2	14	7/8	39 3/4	64	1102
24"	22	31.58	30	16	7/8	46	77	1543

Apply for larger sizes to 48". Flanged valves available with nut operator as option.



## Mechanical Joint with Bevel Gear

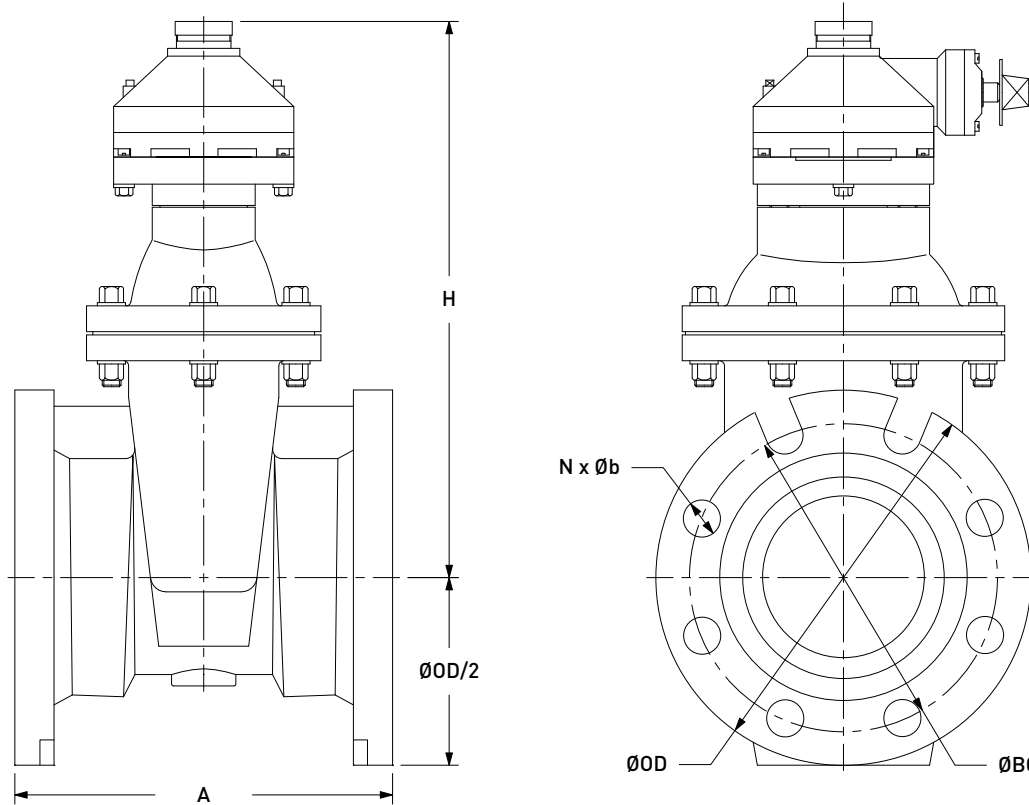

SIZE	A	OD	BC	N	b	H	TURNS*	WEIGHT
2"	8 1/4	6.13	4 4/5	2	3/4	16 5/8	23	-
2-1/2"	8 1/4	6.75	5 2/5	2	3/4	17 5/8	26	-
3"	8 1/2	7.69	6 1/8	4	3/4	18 5/8	33	-
4"	9 1/2	9.12	7 1/2	4	7/8	20	41	-
6"	10	11.12	9 1/2	6	7/8	23 5/8	60	-
8"	10 1/2	13.37	11 3/4	6	7/8	27	79	-
10"	12	15.69	14	8	7/8	30 1/2	98	-
12"	13	17.94	16 1/4	8	7/8	27 3/8	117	-
14"	14	20.31	18 3/4	10	7/8	33 7/8	135	-
16"	18	22.56	21	12	7/8	39 3/4	153	-
18"	19 1/4	24.83	23 1/4	12	7/8	42 7/8	209	-
20"	20	27.08	25 1/2	14	7/8	46	235	-
24"	22	31.58	30	16	7/8	52 1/4	261	-

Apply for larger sizes to 48". Flanged valves available with nut operator as option.

\*Number of turns is applicable to current production model at time of document publish. Previously produced items or with specialty gearboxes may vary.



### Mechanical Joint with Spur Gear

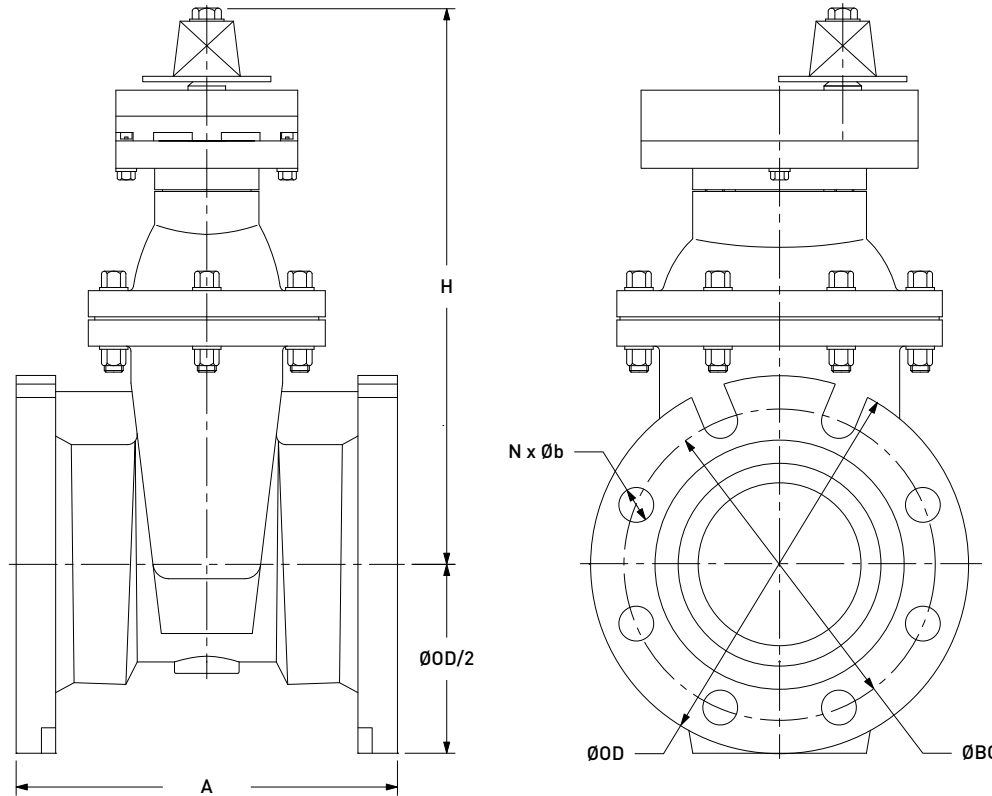

SIZE	A	OD	BC	N	b	H	TURNS*	WEIGHT
2"	8 1/4	6.13	4 4/5	2	3/4	16 5/8	23	-
2-1/2"	8 1/4	6.75	5 2/5	2	3/4	17 5/8	26	-
3"	8 1/2	7.69	6 1/8	4	3/4	18 5/8	33	-
4"	9 1/2	9.12	7 1/2	4	7/8	20	41	-
6"	10	11.12	9 1/2	6	7/8	23 5/8	60	-
8"	10 1/2	13.37	11 3/4	6	7/8	27	79	-
10"	12	15.69	14	8	7/8	30 1/2	98	-
12"	13	17.94	16 1/4	8	7/8	27 3/8	117	-
14"	14	20.31	18 3/4	10	7/8	33 7/8	270	-
16"	18	22.56	21	12	7/8	39 3/4	306	-
18"	19 1/4	24.83	23 1/4	12	7/8	42 7/8	344	-
20"	20	27.08	25 1/2	14	7/8	46	381	-
24"	22	31.58	30	16	7/8	52 1/4	456	-

Apply for larger sizes to 48". Flanged valves available with nut operator as option.

\*Number of turns is applicable to current production model at time of document publish. Previously produced items or with specialty gearboxes may vary.



## Threaded with Nut Operator

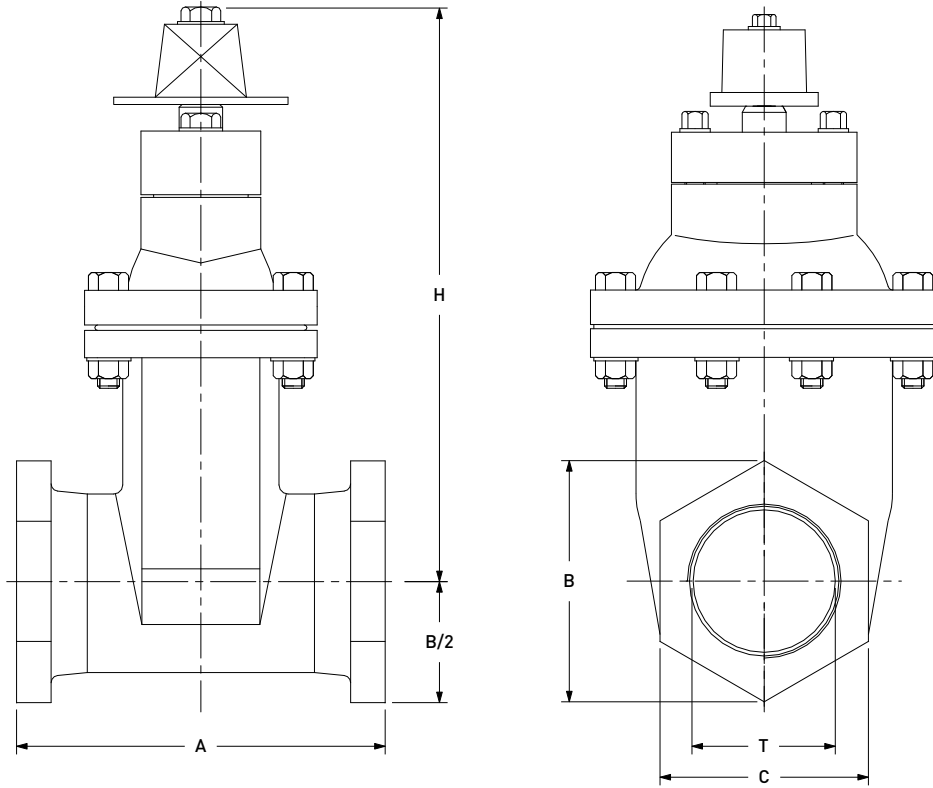

PAGE 18

SIZE	A	B	C	H	T <sup>(1)</sup>	TURNS	WEIGHT
1-1/2"	6 1/2	2 15/16	2 1/2	9 5/8	1-1/2" NPT	7	-
2"	7	3 7/16	3	10 3/8	2" NPT	8	-
2-1/2"	7 1/2	4 7/16	3 7/8	11 3/8	2-1/2" NPT	9	-
3"	8	5	4 3/8	12 1/2	3" NPT	11	-
4"	9	6 1/4	5 3/8	13 7/8	4" NPT	14	-
5"	10	7 9/16	6 5/8	16	5" NPT	17	-
6"	10 1/2	8 23/32	7 9/16	17 1/2	6" NPT	20	-

(1) Taper thread per National Pipe Thread (NPT) standard ANSI/ASME B1.20.1



## Operating Torque

Size	Direct Operator	Bevel Gearbox	Spur Gearbox
2"	26	10	10
2.5"	30	11	11
3"	33	12	12
4"	44	16	16
5"	52	19	19
6"	59	22	22
8"	89	33	33
10"	111	41	41
12"	133	49	49
14"	170	63	63
16"	184	51	68
18"	207	57	57
20"	236	66	66
24"	266	59	74
28"	310	69	57
32"	369	82	68
36"	443	98	82

Maximum operating torque in ft-lbs. Special gears available, apply for information.

## Gate Encapsulation Thickness

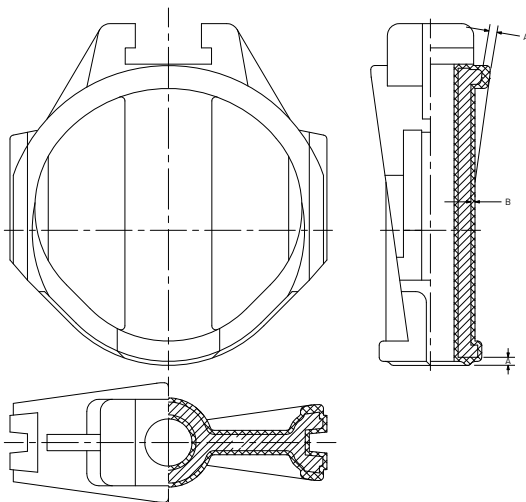

Size	A	B
2"	0.16	0.08
2.5"	0.18	0.08
3"-4"	0.2	0.08
5"-6"	0.2	0.1
8"	0.24	0.12
10"-24"	0.28	0.12
28"-36"	0.39	0.12

Minimum thickness in inches. All rubber encapsulation bonded to ASTM D429.  
A-Seating Surface Thickness



## PART NUMBER MATRIX

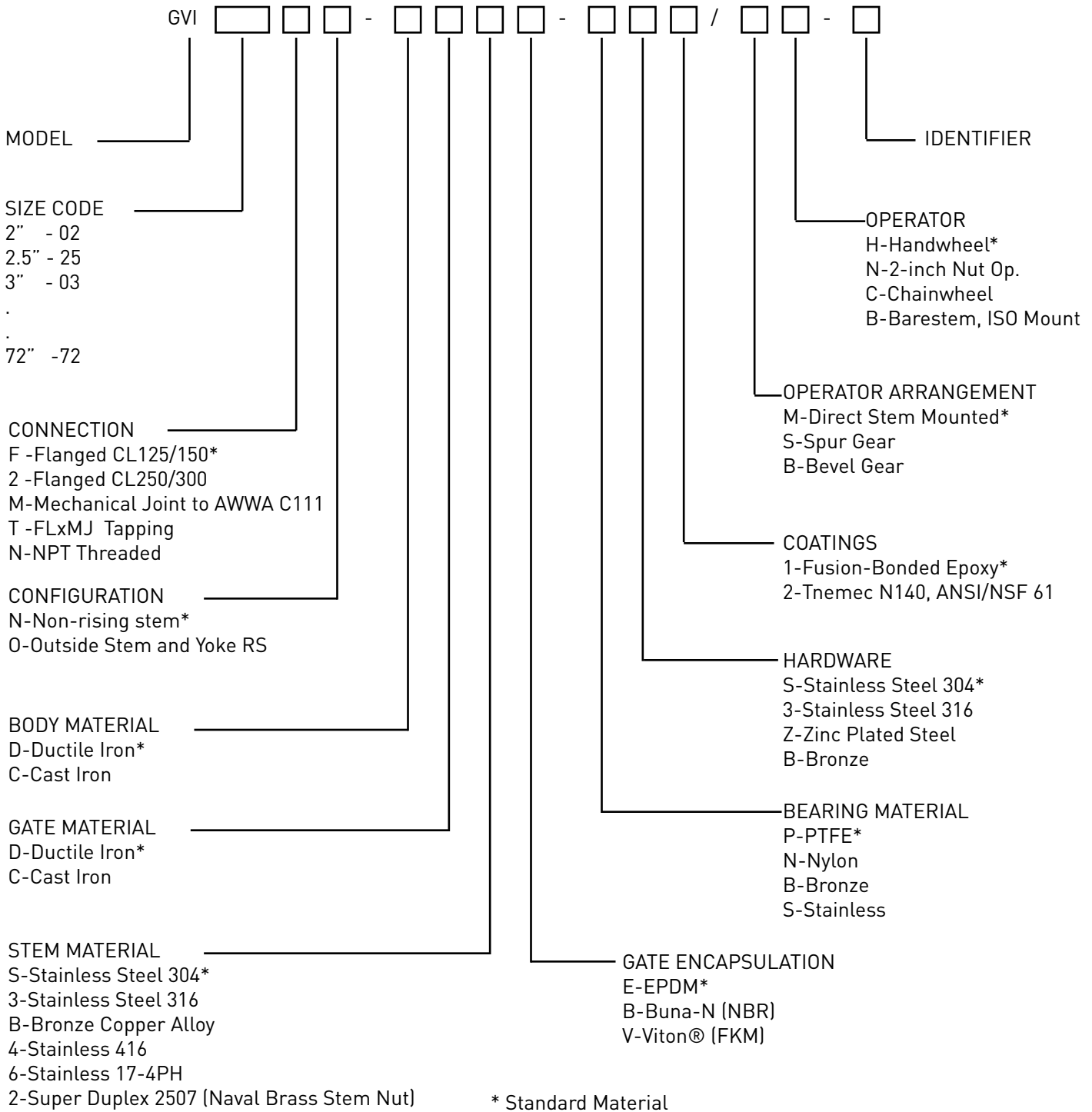

**EXAMPLE:**

**GVI06FO-DDSE-BS1/MH-H**

A 6" flanged OSY gate valve with Ductile Iron body and gate, SS304 shaft, EPDM encapsulation and seals, Bronze bushings, SS304 hardware, fusion-bonded epoxy coatings with direct handwheel operator

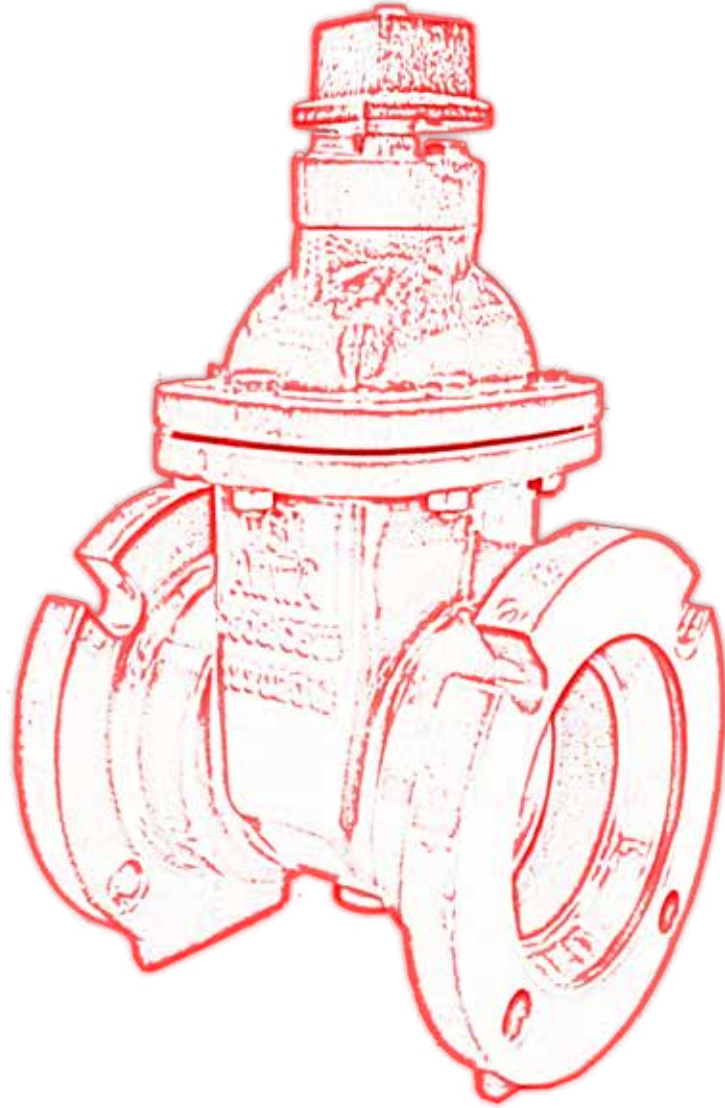

**VSI Waterworks LLC**

**tel: 1 (770) 740 0800**

**fax: 1 (770) 740 8777**

**email: [sales@vsiwaterworks.com](mailto:sales@vsiwaterworks.com)**



**[www.VSIWaterworks.com](http://www.VSIWaterworks.com)**

As part of a process of on-going product development, VSI reserves the right to amend or change specifications without prior notice. Published data may be subject to change. For the latest version, visit our website at [www.vsiwaterworks.com](http://www.vsiwaterworks.com)